

REV	DESCRIPTION	DRAWN	CHECKED	APPROVED

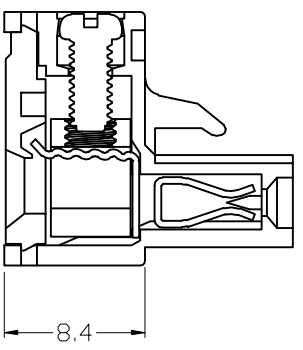
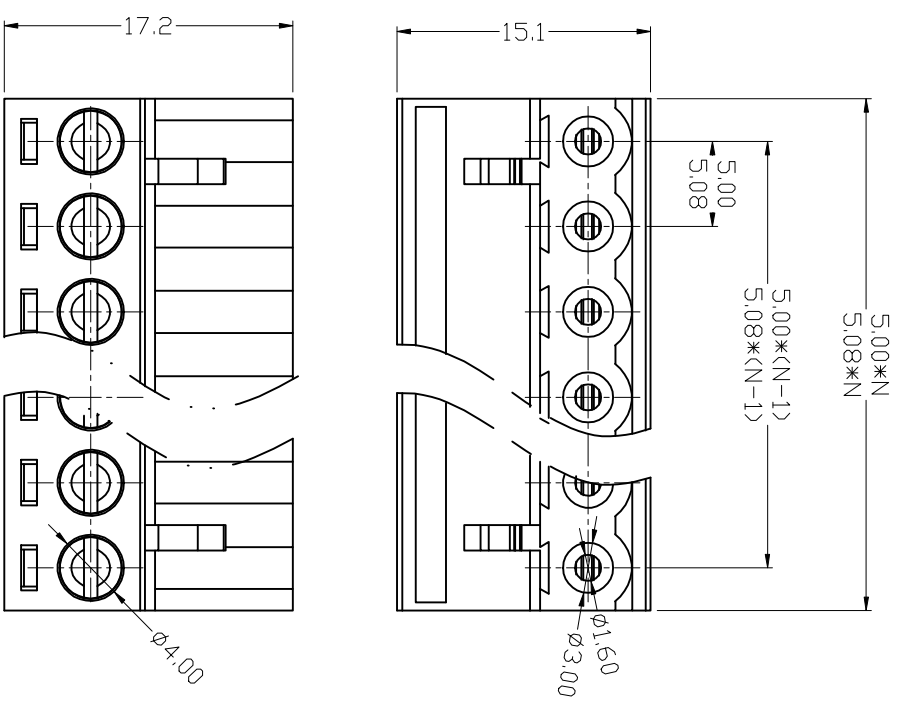

-MATERIAL
 CONTACT : PHOSPHOR BRONZE
 SCREWS : M2.5 STEEL ZINC PLATED
 HOUSING : PA66, UL94V-0

-ELECTRICAL
 RATED VOLTAGE : 300V
 RATED CURRENT : 12A
 CONTACT RESISTANCE : 20mΩ
 INSULATION RESISTANCE : 5000MΩ/1000V
 WITHSTANDING VOLTAGE : AC1500V/1Min
 WIRE RANGE : 28-12AWG 2.5mm²

-MECHANICAL
 TEMP RANGE : -40℃~+105℃
 MAX SOLDERING : +250℃, FOR 5 SEC.
 ORQUE : 0.5Nm(4.5lB.IN)
 STRUOLBERGTG : 7.8mm

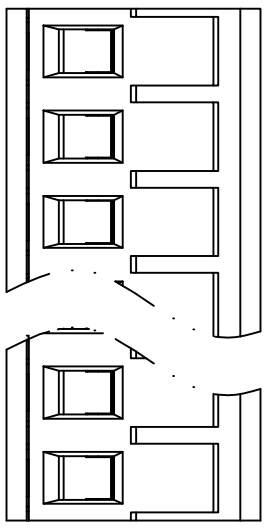

GENERAL TOLERANCE	ANGLE TOLERANCE	PROJECTION UNITS	TITLE	PLUGGABLE TERMINAL BLOCKS
X. ±0.20	X. ±2°	mm		PITCH:5.00/3.08mm
.X ±0.15	.X ±1°	A4	SERIES	KF2EDG
.XX ±0.10	.XX ±0.5°			
DRAWING TYPE	COMPONENTS	慈溪市凯峰电子有限公司 KAIFENG ELECTRONIC CO.,LTD		
SCALE	1:1	SHEET	1	OF 1
DRAWING NO.				